



Certified ISO 9001

OnSite™ 400 Radar Speed Trailer

QUICK START GUIDE



This Quick Start guide explains how to set up your Decatur OnSite trailer and use its key features. Once you're set up you can learn more about Decatur OnSite trailers at www.DecaturElectronics.com.

Find a Good Site

1. Select a site with good road base support. Position the OnSite 400 in a straight line of site from the motorist's view, either before or after a curve and not at a sharp corner. You can secure the trailer to a pole if one is available with the padlock and chain that are included with the trailer.

Set-Up the Sign

1. Lower the four leveling jacks and adjust the trailer to level. Remove the tongue and store it in a safe location or return it to the trailer in an upside down position using a theft-proof pin.
2. Raise the display using the up/down switch marked "LIFT" located on the inside of the control box. When looking at the front of the trailer the control box is located on the left side of the front battery box. The "LIFT" switch is a specially designed safety switch. To enable the switch grab the head of the switch and pull it toward you. It should pull outward. Toggle the switch up and hold. The display box will begin to raise into position. Once all the way up, let go of the switch and push the head of the switch back in disabling the switch. When raising and lowering the lift be sure and observe the pinch points.

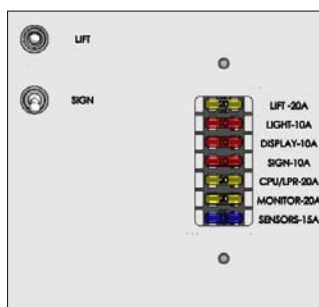

Figure 1

Location of LIFT Switch in the Control Box

Power-Up the Sign

1. Turn the main power switch to the "ON" position. The main power switch is located inside the front storage box on the side wall. Before moving the trailer to another location make sure the switch is returned to the "OFF" position.

2. Turn on the radar speed display. The power switch is inside the display control box (Figure 2) located on the right side of the display. If connected, the EZ-Stat module will also be powered on.
3. The trailer has additional options available. If your trailer has been equipped with a variable message board, directional arrow stick, etc. these options can now be turned on.



Figure 2

Display Box Switches

Setting the PushWheel Switches

1. Set the High Speed Cut Off switch to the maximum speed you want the sign to display. No speeds will be displayed above this setting.
2. Set the Violation Speed switch to the speed you want the sign to flash at. Once that speed (or a higher speed) is reached the speed will flash on/off in the display.

Testing the OnSite 400 display

Pressing the TEST button when the trailer is on will check the digits. The display will show "88" or "188" depending upon your display.

Testing the Violation Speed and High Speed Cut off Functions

1. Make sure the power switch in the Display Box is OFF.
2. Press and hold the TEST button while switching power ON.
3. Release the TEST button.

The unit will count from 0-99 (or from 0-199 depending upon the display). When it reaches the pre-set violation speed the display will flash and when it reaches the cutoff speed the display will blank. It will then continue to count until you switch the power OFF and back ON to reset the display. (Refer to the user's manual for more information on testing and using the OnSite 400.

When moving the trailer reverse the power-up and set-up steps.